

OUTBOARD ENGINE TEMPERATURE KIT

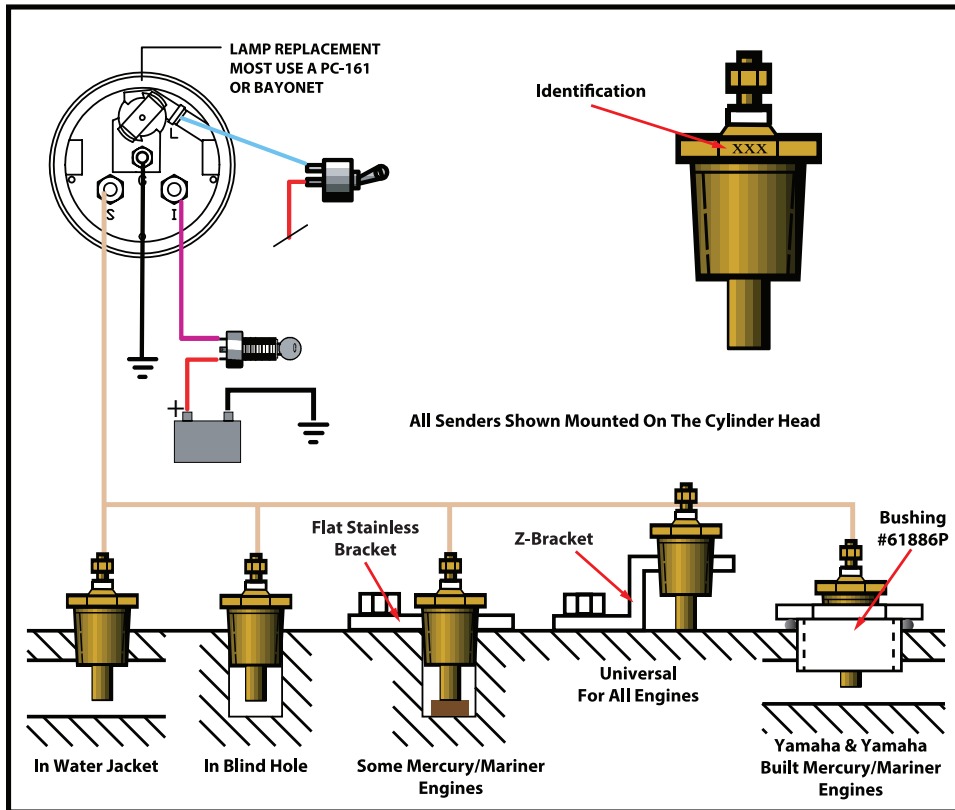

Some engines have a blind threaded hole for the sender that does not enter the water jacket. Apply a thermal grease in the hole and thread the sender snugly in the hole, again using no sealer. Check with engine dealer or your local marina for recommended thermal grease.

Some Mercury engines have a blind hole flanked by two bolts. First apply thermal grease in the hole, drop in the aluminum spacer, and secure the flat bracket with the two bolts. Thread the sender into the bracket against the spacer.

The Z-Bracket is the most often used as it can be used on any engine. The bracket through hole is held by a cylinder head bolt. The sender is threaded into the remaining hole against the cylinder head to assure good thermal transfer.

Yamaha engines require metric bushing P/N 61886P (sold separately) threaded into the cylinder's 14 mm hole. Re-use

Gauge part number is on the side of the housing.

The temperature monitoring kit includes all parts to adapt to any of the situations shown. Yamaha engines will require adapter P/N 61886P in addition to the kit. Honda offers its own bushing.

Because outboard engines use raw water for cooling and are mostly aluminum, they operate cooler than I/O engines. Consult dealer as to the operating temperature for your engine.

The sender in the kit has 1/8-27 NPT threads and an I.D. Code of "010" or "60" stamped on the hex. Part numbers are:

- Sender - 52320S010 (Sierra P/N - 18-5896)
- Flat Bracket - 54552
- Z-Bracket - 1A55009

Some engines include a threaded hole directly into the water jacket. The sender can be threaded into the hole, using no sealant on the threads. The threads create the electrical ground.

the plug O-ring on the bushing. The sender in the O/B Temperature Kit can then be threaded into the bushing.

The kit is supplied with one sender. If a sender is desired on each cylinder head of a V type outboards, a double pole ON-ON switch must be used to switch sender inputs to the gauge. The gauge cannot accurately read two senders at one time.

Testing the gauge for operation: Connect hot wire to "I" and ground wire to "G". Turn the key ON position. Gauge should read below C. Next, with the key still in the ON position, short "S" to "G". Pointer should read above H, If the pointer sweeps both ways, the gauge is fine.

Testing the sender: At room temperature, no wires connected to the top of the sender, it should measure 600-1000 ohms on a test meter.